

***For Power Companies
And The Electrical Industry***



Vacuum Oil-Purifiers



Cargo Trailer Mount Option

Performance

The typical performance in a **single pass** through an Enervac vacuum system is as follows:

- Dehydration—At minimum oil temperatures of 80° F the water removal is from 100 ppm to less than 10 ppm.
- Degasification—Enervac vacuum oil purifiers reduce soluble air content in a single pass from full saturation of approximately 12% to less than 0.25%. Other gases in solution with oil, including combustibles, are also removed.
- Particulate matter—The accelerator cartridge provides removal of particulate matter to a nominal 5-microns. The addition of a filter downstream of the chamber will remove particulate matter to submicronic size.
- Other contaminants such as products of oil oxidation, thermal degradation, dissolved varnishes, paints and acids can be removed by the addition of Fullers Earth filters to the system.

Applications

The most important applications of high vacuum degasifiers are in the field of extra high voltage transmission and in the manufacture of electrical apparatus for it. In addition, the high vacuum process is used in the degasification of cable oils including polybutenes. Outside of the electrical industry, this process is used for dehydration and degasification of oils for radar and electronic equipment, vacuum pump sealing oils, brake fluids, refrigeration oils—including phosphate esters and silicones.

Enervac offers the E865A Vacuum Oil-Purifier series designed for maximum efficiency in your operations...performance tested by experts, requiring minimum maintenance, and providing long, trouble-free service.

Backed by the full resources of Enervac's technical specialists, plus "know-how" and thorough research, your Vacuum Oil-Purifier is unique. Designed for unattended operation and suitable for operation on energized equipment—complete monitoring equipment is also available.

Description Of Process

Oil, at ambient or elevated temperature, is introduced into the vacuum chamber, where by vacuum distillation, water, dissolved air and gases, and other low-boiling-range volatile contaminants are removed.

Special chemically inert accelerator cartridges in the vacuum chamber are employed to serve the following functions:

First, their in-depth design structure allows free water to be rapidly separated from oil by coalescence even before it reaches the evaporation stage.

Second, millions of glass fibers 3-10 micrometer diameter provides a large total surface area for exposure of the thin oil film to the vacuum.

Third, sharp points of the glass fibers promote fast release of gases and vapors from oil.

Fourth, the elements act as a fine filter removing solid contaminants. The cartridges are easily replaced and disposable.

This method is more efficient than previously used spray nozzles and baffles, which required several passes to obtain the same degree of degasification.

Present and future transformer ratings require high quality and a great degree of purification of insulating oils at the point of use.

The increasing voltage and rating of the modern transformer and electrical apparatus results in greater electrical stress in insulating material and fluids. To handle these greater stresses, oils with better dielectric quality are required, and lower residual water content in insulation must be maintained.

The proper treatment and upgrading of the insulating fluid will result in the improvement of the properties of the entire insulating media of power transformers.

The principal functions of the insulating liquid are to serve as a dielectric material and an effective coolant. To perform these functions, the insulating liquid must have the necessary qualities at the time of initial impregnation and filling at the factory and later maintain the same quality in the field operation.

The Enervac High Vacuum Process upgrades the new or used electrical insulating liquids including transformer oils, polybutenes and silicone fluids.

These systems and equipment were developed as a result of 40 years of experience in vacuum treatment of electric insulating oils.

High Vacuum Process is used for dehydrating and degasification of electrical insulating fluids to increase and maintain their dielectric strength. The processing includes the removal of free and soluble water, free and dissolved air and gases, and particulate matter.

By the application of corrective filters, which remove soluble varnishes, resins and products of oil oxidation, the oil quality can be further improved.



Lifting Frame with Tarpaulin Option

VACUUM OIL-PURIFICATION SYSTEMS

Model Nomenclature Chart

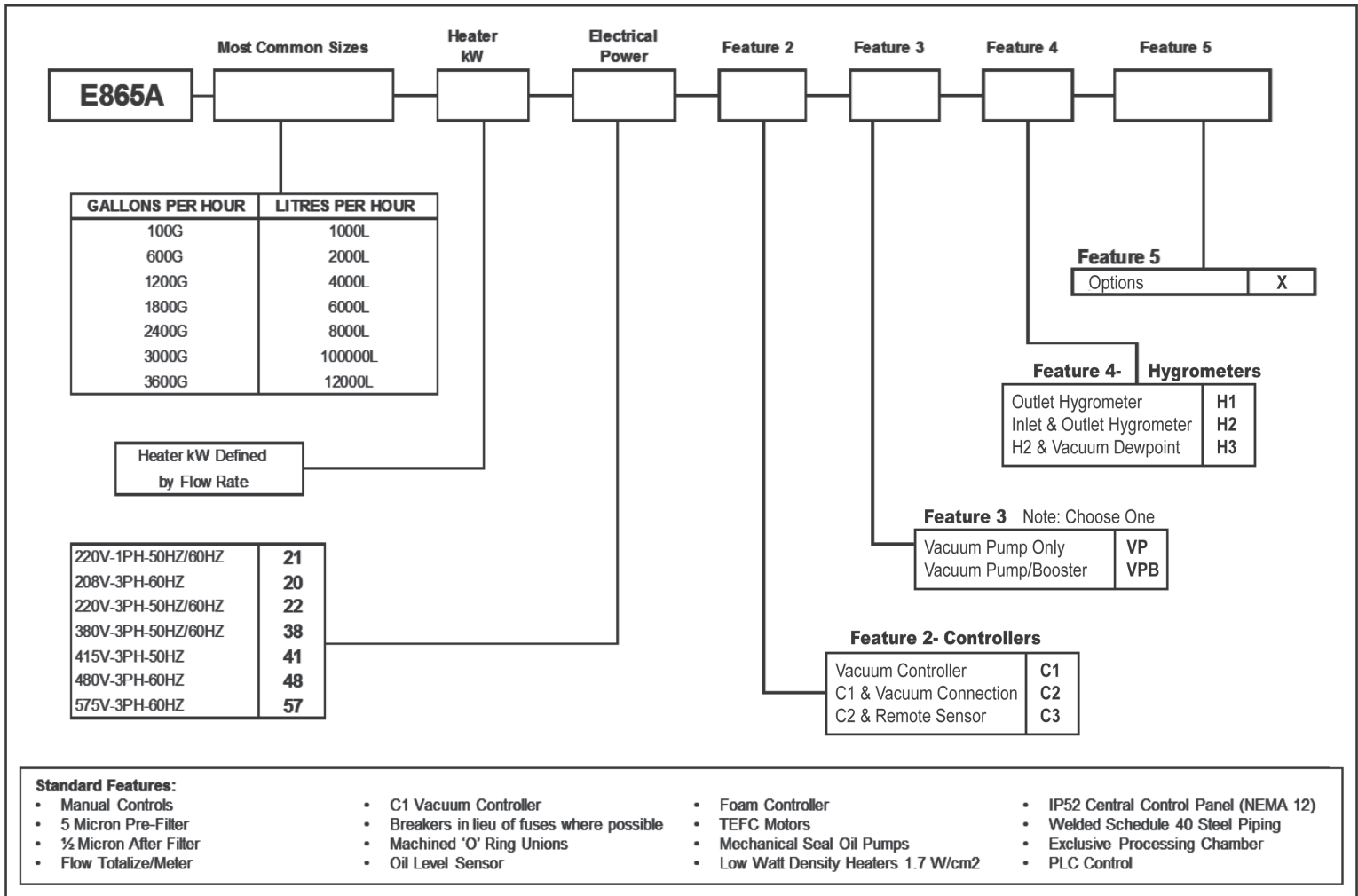

Open-Sided Container Mount Option

& TRANSFORMER DRYING EQUIPMENT

Options

ENERVAC units are extremely customizable, some of the options that are available include:

- Extra heater capacity for faster temperature rise
- Outlet heater to assist in maintaining transformer temperature
- Diesel boiler to minimise power consumption
- Viton gaskets
- Dual control system
- Fuller's earth/regeneration connections
- Dry Air systems, breathable options
- Onboard power generator
- Onboard fullers earth system (E575A series)
- Inline dielectric strength tester
- Inline gas analyzer
- Fully air-conditioned operators cabin
- Data logging & reporting
- Remote monitoring
- Chilled trap
- Interstage chiller
- Wireless emergency dial out, email, SMS text
- Touchscreen HMI controls
- TOLMS (Transformer oil level monitoring system) for energized transformers
- Reverse flow changeover valves
- Hose storage reels or live reels
- Power cable storage reel or live power reels
- Multi-voltage power input
- Oil mist eliminator
- Interstage condenser
- Refrigerated cold trap
- Full aluminum trailer, from tagalong up to 53ft semi-trailer
- Soft-side tarpaulin tagalong trailer
- Container Mounted or soft side lifting frame
- EEx or NEMA 7 explosion-proof
- Full stainless-steel option



Semi Trailer Mount Option

**RECOVERY AND PURIFICATION SOLUTIONS THAT
WORK FOR YOUR BUSINESS**

280 Holiday Inn Drive, Cambridge, Ontario, Canada N3C 1Z4 (P) 1-519-651-1034 (F) 1-519-651-1038
www.enervac.com / sales@enervac.com